

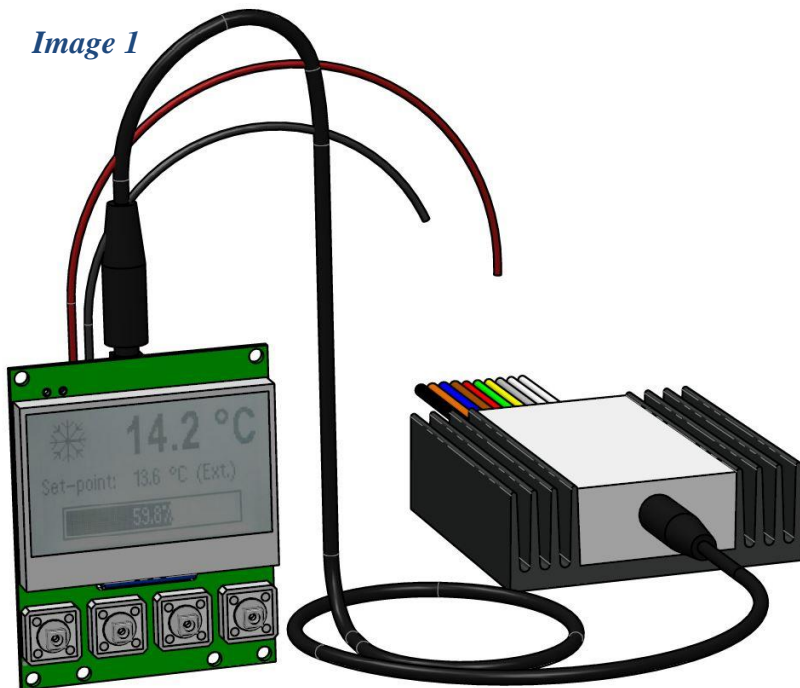

Manual: Display-QC-PC-D-CH1

Image 1



Display

[QC-PC-D-CH1](#)

Peltiercontroller

[QC-PC-CO-CH1](#)

Deliverables:

- 1 Display QC-PC-D-CH1
- 1 Manual
- 1 Connecting cable

Technical specifications

Power Supply:

- U_{supply} : 12VDC...24VDC
- I_{supply} : ca. 40mA...25mA
-

Menu-Languages:

- Deutsch
- English
- Français
- Dutch

1. Intended use of the Display QC-PC-D-CH1

The display is used to show the control status and to program the controller [QC-PC-CO-CH1](#). The display must be connected to the controller via the connecting cable supplied. The display shows the temperature setpoint and the currently measured temperature value. In addition, the display provides information about the current control and the mode of the temperature setting. Use the D button ([*Image 3*](#)) to access the easy-to-understand, four-language menu. All modifiable parameters can be set here.

2. Display Connection

To connect the display to the controller, the supplied cable must be plugged into the socket of the controller and the display. In addition, the display requires a supply voltage. This voltage must be connected to the screw terminals. The contact assignment can be seen in the picture [*Image 3*](#). Correct polarity must be ensured.



3. The Menu

Main Menu Menu level 1	Menu level 2	Menu level 3	Menu level 4	Factory settings	
Control settings	Control mode	Fixed (<i>Setpoint via display</i>) External (<i>Setpoint via potentiometer</i>)		External	
	Temperature set-point <i>Available only in Fixed-Mode</i>	-40°C – 100°C		20°C	
	Set-point minimum <i>Available only in External-Mode</i>	-40°C – 100°C		-40°C	
	Set-point maximum <i>Available only in External-Mode</i>	-40°C – 100°C		100°C	
	Hysteresis	0.0°C bis 100,0 °C		0.2°C	
	Cooling settings	Bandwidth cooling		0.1°C – 100°C	1.0°C
		Min. cooling output		0% - 100%	0%
		Max. cooling output		0% - 100%	100%
	Heating settings	Bandwidth heating		0.1°C – 100°C	1.0°C
		Min. heating output		0% - 100%	0%
Max heating output			0% - 100%	100%	
PWM frequency	1kHz; 5kHz; 10kHz; 15kHz; 20kHz; 25kHz			10kHz	
Digital output <i>Experts only! (Image 2)</i>	Off / Idle mode / Cooling mode / Heating mode / Idle mode (inv) / Cooling mode (inv) / Heating mode (inv)			Off	
Sensor settings	Temperature offset	-10°C - +10°C		0.0°C	
Save settings	Save all settings <i>securely</i>	Settings successfully saved to target device. >OK<		!	
	Factory defaults	Proceeding will reset all settings on target device to factory defaults. >No Yes<		!	
System	Language	French / German / Dutch / English		English	
	LCD contrast	0% - 100%		50%	
	LCD backlight	Off / Dimmed / On / 15 seconds / 20 seconds... / 300 seconds		150 seconds	
	Factory defaults	Proceeding will reset all settings to factory defaults. >No Yes<		!	
	Software version	<i>Info</i>			
	Factory service	Enter password 0000			

3.1 Navigate in the Menu

- A** One menu level back
Exit menu
Discard parameter change
- B** Jump >down<
Parameter value >reduce<

- C** Jump >up<
Parameter value > increase<
- D** Call up menu
Jump in menu level
Apply parameter setting and save
volatile

3.2 Save settings

Exit without saving: The parameter setting can be cancelled by pressing the A key. Changes that have not already been confirmed with D are discarded.

Temporary save: If a parameter has been changed, it is immediately, temporarily accepted with key D. After an interruption of the supply voltage, this setting is lost and the last to memory written parameter set becomes active again.

Write to memory: The parameter set is saved to the permanent memory via the Save settings in the main menu.

3.3 Important

Control mode: If *Fixed* is selected, the target temperature can be set via button on the display. The potentiometer then has no function. If the potentiometer is not connected, the associated cables must be electrically insulated.

If *External* is selected, the potentiometer must be connected. The target temperature is then dependent on the potentiometer setting.

Hysteresis: Regardless of the parameters, the output is then switched off when the target temperature is reached. The output is then only switched on again when the setpoint is exceeded or undershot by the value of the hysteresis.

Bandwidth: The bandwidth describes the width of the linear ramp function over which the control algorithm calculates the PWM ratio. *Diagram 1*

4. Control Characteristic

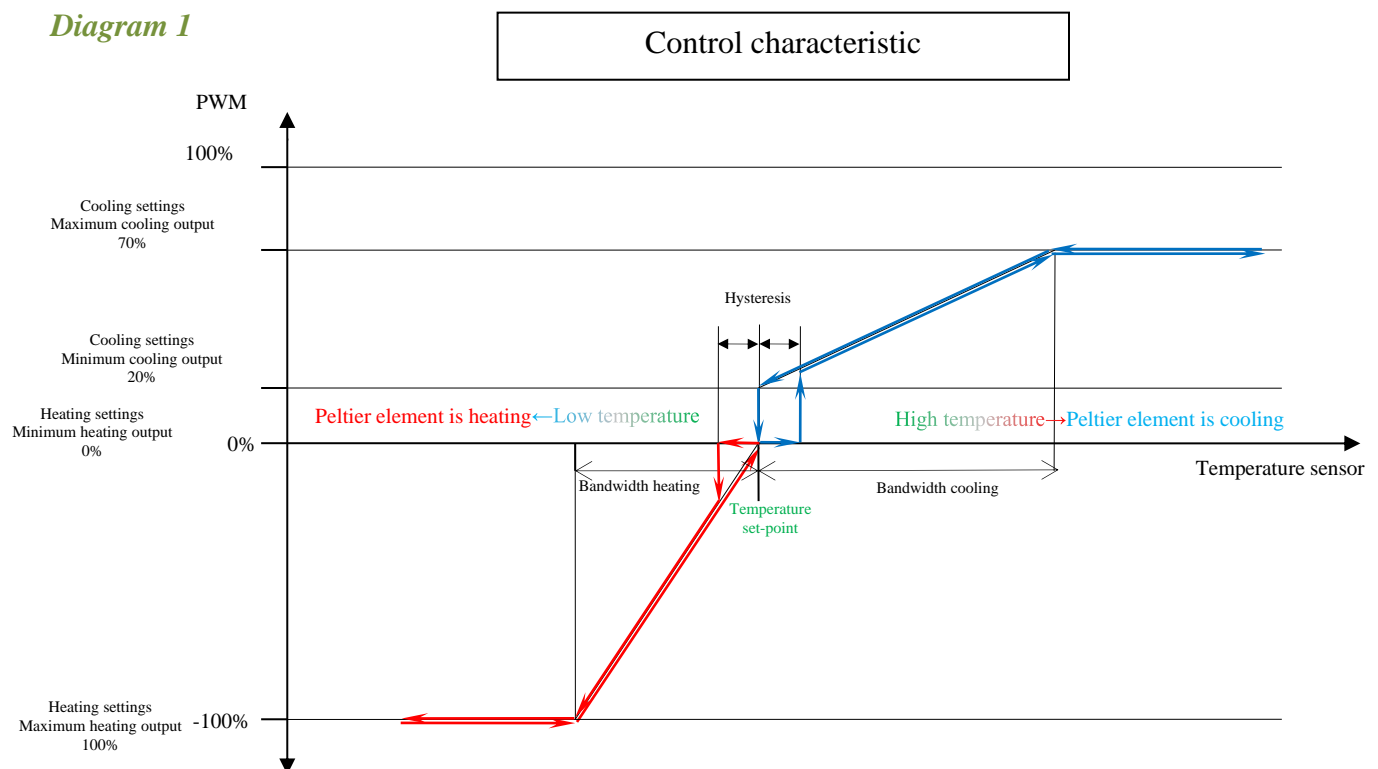

The heating and cooling parameters can be set independently of each other. The effect of the parameter changes is shown graphically in *Diagram 1* using an exemplary parameter set.

5. Error messages:

Not connected: Communication not possible

Possible causes: Jack plug not inserted correctly

Consequence: The controller continues to operate. Parameterisation not possible. Control values are not displayed

PSC: Sensor resistance low

Possible causes: Sensor short cut, sensor defect or high temperature

Consequence: The current flow to the Peltier element is interrupted

NP: High sensor resistance

Possible causes: Sensor wire broken, sensor defect or low temperature

Consequence: The current flow to the Peltier element is interrupted

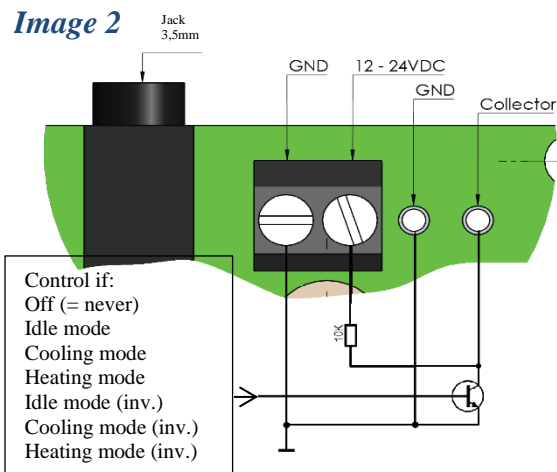

Digital Out

For the internal wiring at the digital output, please refer to **Image 2**. The transistor is activated at the programmed control status. Then the collector is connected to earth. Otherwise, the supply voltage is applied to the collector via a 10KΩ resistor.

Only use this output if you are qualified.

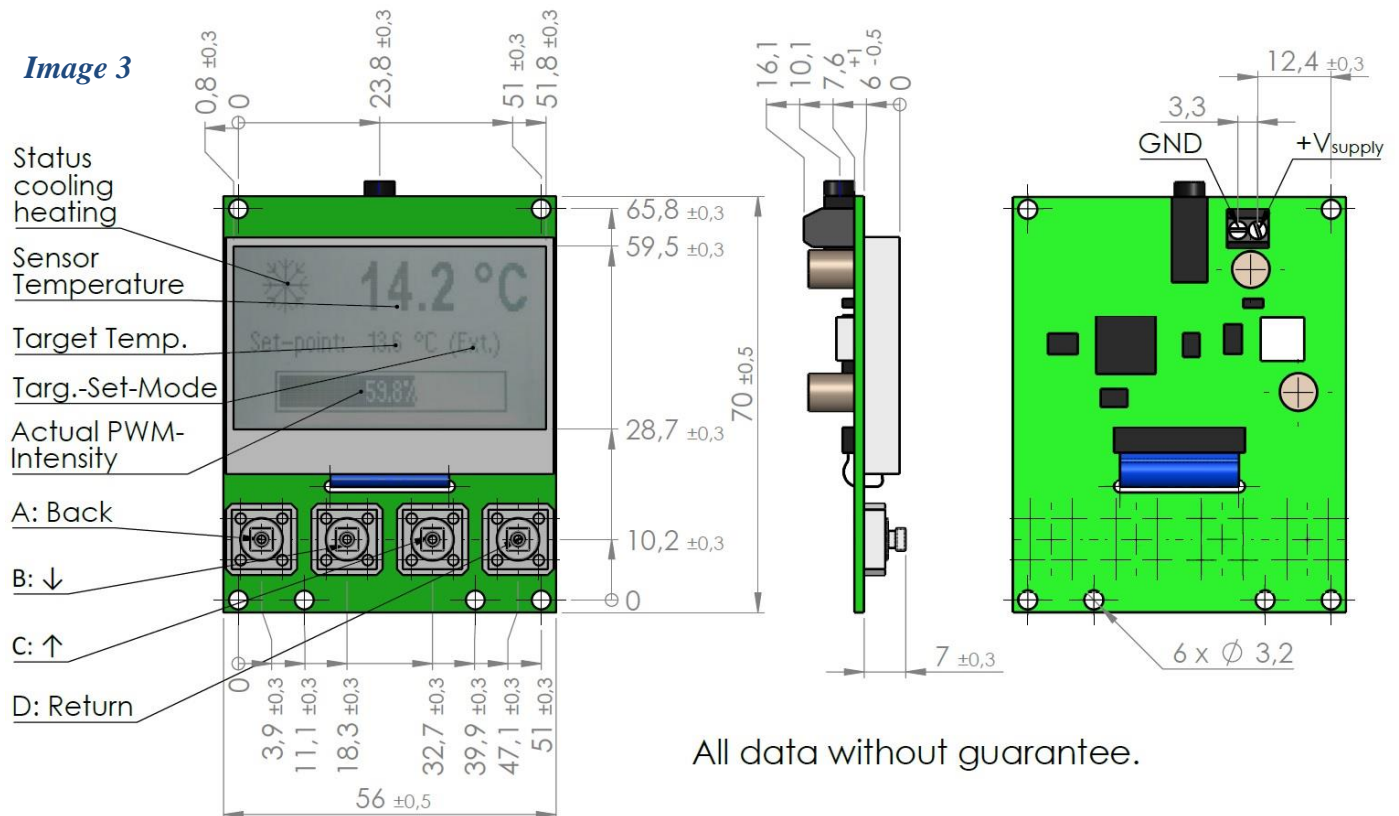

All data without guarantee.